

0 611 316 8K0 – GSH 11 E

Material number	0 611 316 8K0
EAN	3165140962629
Auxiliary handle 2 602 025 076	✓
Carrying case 2 605 438 297	✓
Flat chisel 400 x 25 mm 1 618 600 202	✓
Grease tube spare part number 1 615 430 010	✓



Technical data

Technical data

Rated input power	1.500 W
Impact energy (according to EPTA 05/2016)	16.8 J
Impact rate at rated speed	900 – 1,890 bpm
Weight	10,1 kg
Tool dimensions (length)	270 mm
Tool dimensions (height)	270 mm
Tool holder	SDS max
Tool dimensions (width)	570 mm
Product category subdivision	Demolition Hammer with SDS max

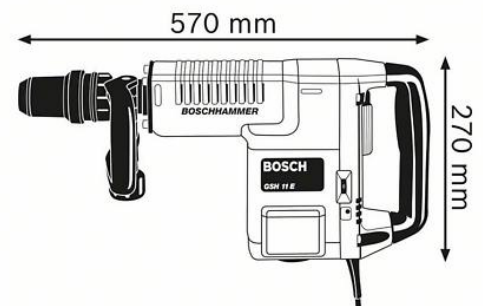

Noise/vibration information

Noise level	The A-rated noise level of the power tool is typically as follows: Sound pressure level 89 dB(A); Sound power level 100 dB(A). Uncertainty K= 3 dB.
-------------	---

Sales information

Positioning

- The specialist tool for breakthroughs and demolition work

User benefit

- Extreme impact force of 16.8 joules for high material removal rate
- Low-vibration in operation and no-load
- Low feed pressure, for fatigue-free working

